



For Earth, For Life
Kubota

R

KUBOTA WHEEL LOADER **R630**

A bold redesign emphasizing comfort and efficiency, with a spacious cab, powerful Kubota engine, and superior maneuverability.



From Kubota, comes a new wheel loader designed to get the you working comfortably. It's all-new, inside and out, and rea

POWERFUL AND COMFORTABLE LOADER



Operator comfort

The spacious cab provides plenty of leg and elbow room, while the controls are ergonomically arranged for quick and easy access. It's all designed to keep you working efficiently from start to finish. Optional air conditioning will keep you working comfortably all year round.

**job done faster and keep
dy for any job you give it.**

WHEEL

Kubota original engine

The R630 is powered by a robust Kubota-built 61.2 HP diesel engine. The eco-friendly engine is fitted with a diesel particulate filter (DPF) muffler, complies with TierIV regulations for exhaust emissions, and features low noise, low vibration, and low fuel consumption.

Performance

You'll get the job done efficiently, thanks to the tough and reliable Kubota-built engine and flexible electronic hydrostatic transmission (HST) with four operating modes, each optimized to handle a specific type of loading work. You'll also get excellent breakout force and superior maneuverability, as well as excellent stability in most all types of working conditions.

Safety and security

The OSHA-certified ROPS/FOPS canopy and cab provide protection in the event of accident. Six tie-down points ensure simple and secure transportation between sites.

Serviceability

Fast and easy access to all daily inspection items ensures the R630 will be back on the job as quickly as possible.



SUPERIOR PER

An optimum balance of power, functionality and performance lets you work more efficiently.

Electronic Hydrostatic Transmission (HST)

Loader work is smooth, fast and efficient, thanks to Kubota's electronic hydrostatic transmission. Its four operating modes are optimized to handle specific types of loading work, allowing selection of the right mode for every loading job you do.

Normal mode

Normal mode lets you quickly start loading, carrying, collecting sand/gravel, and performing other jobs.

Eco mode

Eco mode improves fuel efficiency by 10 -15%, letting you work longer between refueling stops. Better fuel efficiency is better for the environment as well as your budget.

Power mode

For piling, excavating, and other jobs that require extra traction force. Power mode increases traction force by 40%.

Attachment mode

Choose attachment mode when working with a sweeper, mower, etc. You can then set and maintain a precise attachment speed by using the engine speed (AUX flow) control dial that is independent of the travel speed. In addition, the attachment mode provides travel speeds up to 3.0 mph in five steps.



Aux hold switch: A simple push of the Aux hold switch sets and maintains the hydraulic oil flow for the implement. (All modes)



Engine speed (AUX flow) Control dial: 1050 - 2400 rpm (Attachment mode only)

Lower clearance

A low clearance—just 8.2 feet—means the R630 can work under low-hanging branches, eaves, and other hard-to-get areas, as well as travel between jobs under low bridges.



Multi-function operating lever

All major loader functions are on a single lever that is easy to operate with just one hand. The 5-step speed control switch let you quickly change speeds and work at the optimum speed for the task.

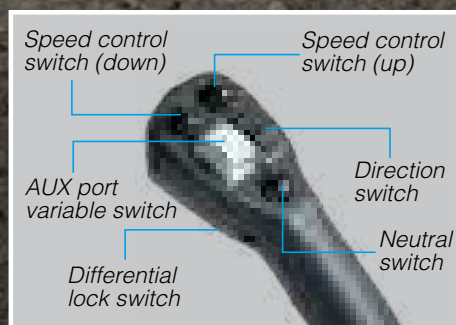

PERFORMANCE



Working range

A long dumping reach and high dumping clearance make all types of dumping jobs easy. The long dumping reach and high dumping clearance lets you dump into truck beds with ease, while the long dumping reach makes pallet fork operations faster and more efficient.

Hybrid link design

The well balanced cylinder position of the Kubota hybrid link system combines the advantages of both Z link and parallel link systems. You get strong bucket force when excavating and grading and vertical lift path for superior reach and lifting. Transporting a full loaded pallet with the pallet fork, Kubota's hybrid link system structure keeps the load upright and steady, even while raising or lowering the lift arms.

Articulation and frame oscillation

For greater stability and more comfort when operating on rough terrain, a unique center-type joint allows for 8° of frame oscillation and 40° of articulation in either direction. Plus, the heavy-duty components ensure long life operation.

Differential Lock (100% on demand, front + rear)

To counter act wheel slip, simply press the differential lock switch to immediately engage both front and rear wheels. The result is positive, slip free traction.

ROPS/FOPS cab and canopy

Forged and attached at the Kubota factory, both the Roll-Over Protective Structure (ROPS) and Falling Object Protective Structure (FOPS) meet the applicable ISO, SAE and OSHA standards.

DELUXE INTERI

A new level of operator comfort helps you work more efficiently and with less fatigue.

High-visibility cab

All-new designed cab features a fully enclosed glass to improve visibility in all directions. The full-glass left-side door and wide-opening right-side window provide clear views of the conditions outside. The rear of the cab features rounded glass corners that, combined with the sloped bonnet, provide excellent visibility when reversing. Up front, a wide view and a redesigned Z-bar linkage configuration give you unobstructed views of the quick coupler from the driver's seat.

Modern digital display



Bright and easy-to-read digital instrument panel displays machine function and status at a glance. A full set of diagnostic indicators automatically monitor critical machine conditions, letting you concentrate on the job at hand.

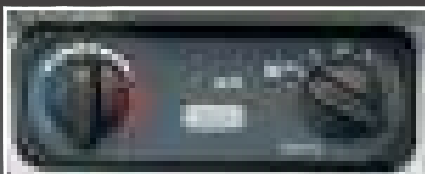

Air conditioning (Standard for cab models)

A powerful cooling/heating unit and multiple vents help improve overall air circulation for better all-round operator comfort. Four defroster vents—two each for the front and rear windows—enhance demisting on cool, damp mornings.



-  Air conditioning (heating/cooling)
-  Defrosting
-  Heater only

OR



Full-suspension seat

A full-size, full-suspension adjustable seat enhances operator comfort. The padded seat can be moved forward or back for optimum comfort.

Tilt steering

With the flick of a lever, the steering wheel can be tilted up or down to the most comfortable and efficient position for drivers of all sizes.

Adjustable right wrist rest

More than just a place to put your arm, the right-side wrist rest. It reduces fatigue by minimizing arm movement and allowing you to more easily operate the multi-function lever.

MAINTENANCE

Maintenance and safety features let you work safer and more securely.

Easy maintenance

Convenient service access on the Kubota R630 helps to reduce downtime and maintenance costs and lets you get back to work as quickly as possible. The engine bonnet at the rear opens wide, providing quick and easy access to the machine's main service areas. Components that require routine maintenance and service, such as dual-element air cleaner, engine oil refill, fuel filter and water separator are within easy reach for fast and simple servicing. Quick-open panels on the right and left sides provide speedy access to the fuel refill (right side) and battery (left side). Other areas of the R630 are also easy to service and maintain.

Digital diagnostic indicators

A bright easy-to-read digital diagnostic indicator keeps you fully informed of critical loader and engine conditions.

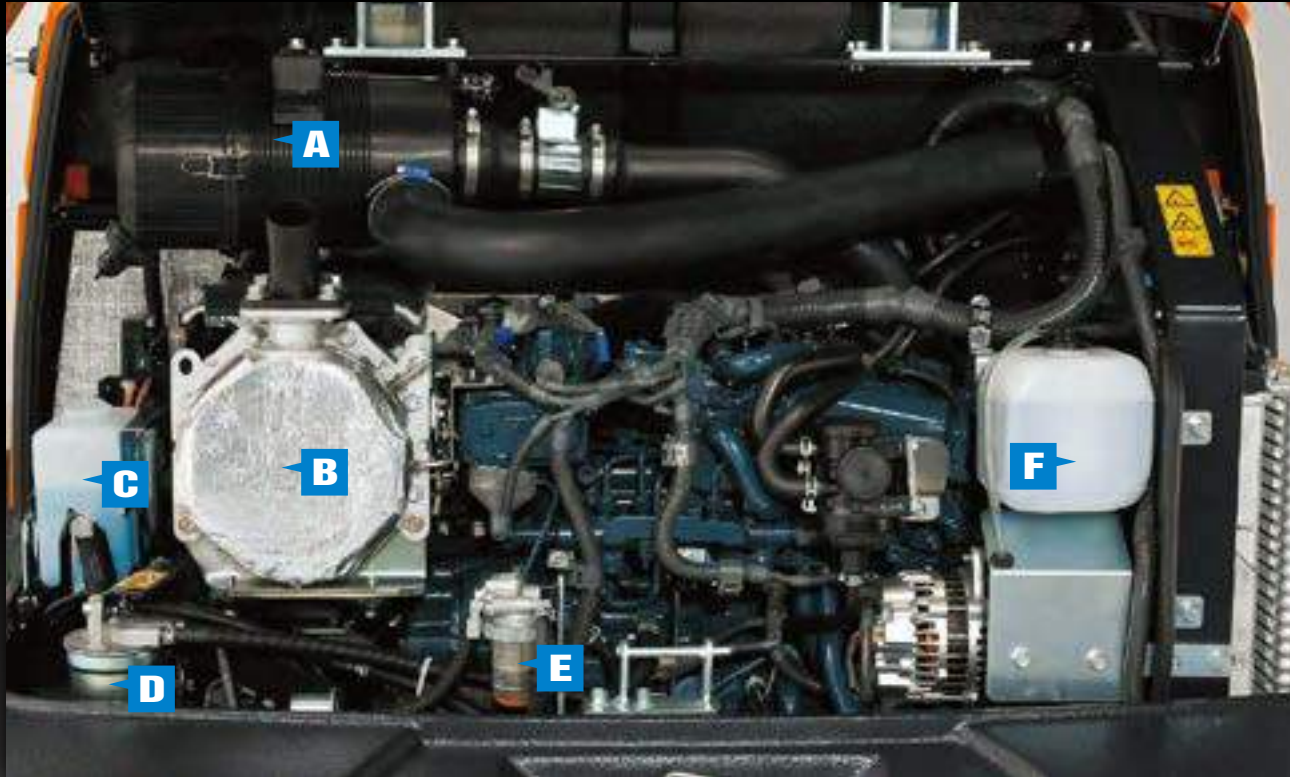
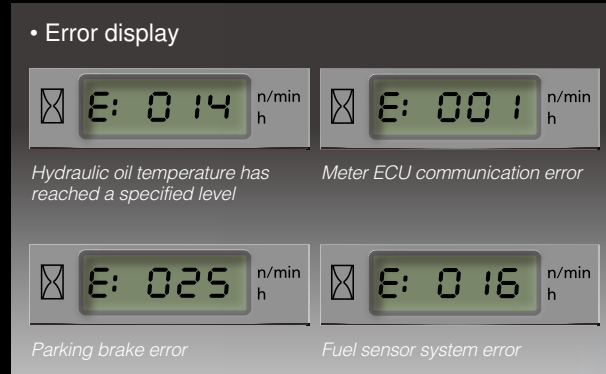

A Dual Element Air Cleaner

B Diesel Particulate Filter (DPF) muffler

C Washer Tank

D Fuel Filter

E Water Separator

F Reserve Tank

Common Rail System and Diesel Particulate Filter (DPF) muffler

The Common Rail System (CRS) electronically controls the fuel injection timing and amount in stages rather than all at once for optimal combustion. The results are greater efficiency, better fuel economy and less engine noise. Its combination with the Exhaust Gas Recirculation (EGR) and Diesel Particulate Filter (DPF) Muffler reduces harmful emissions to make the R630 Tier IV-compliant.

Automatic regeneration system

Kubota's original automatic regeneration system automatically burns accumulated particulate matter (soot) in the DPF muffler to keep the muffler clean for longer operation. Automatic regeneration can be turned off with the inhibit switch when the wheel loader is operating in areas that have materials with potential for combustion.



WORKING RANGE

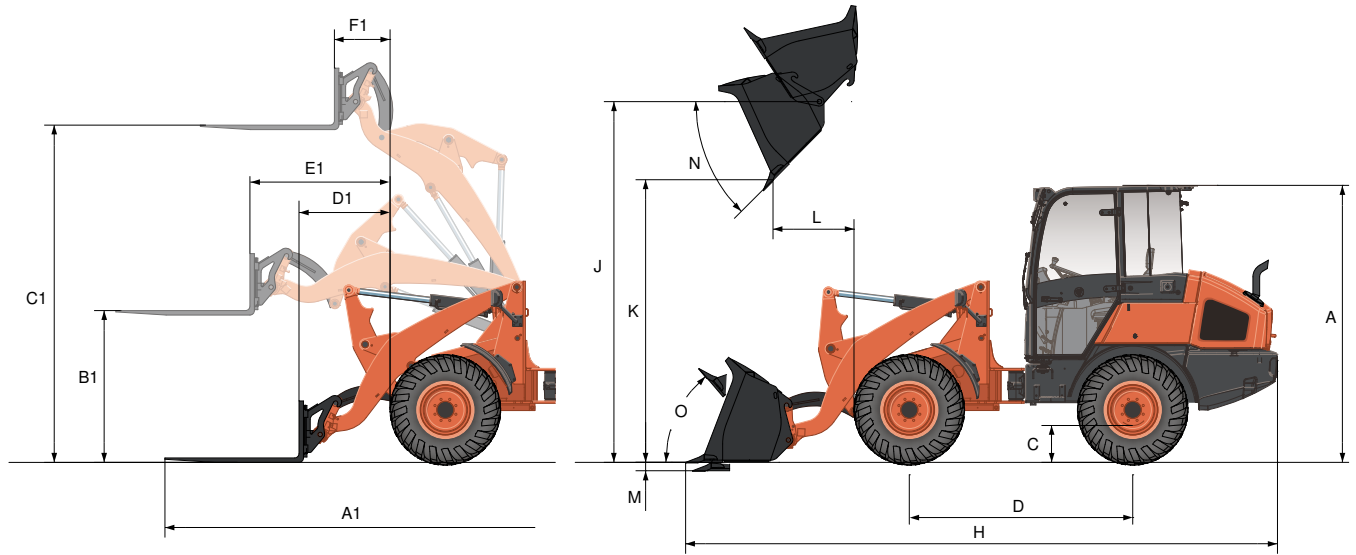

DIMENSIONS

A	Overall height	ft.in. (mm)	8' 2" (2480) / 8' 2" (2500)
B	Overall width (w/o bucket)	ft.in. (mm)	5' 11" (1805)
C	Ground clearance	in. (mm)	13.8" (350)
D	Wheelbase	ft.in. (mm)	6' 7" (2000)
E	Tread	ft.in. (mm)	4' 7" (1400)
F	Loader clearance circle (w/ std bkt)	ft.in. (mm)	27' 3" (8295)
G	Turning radius track circle	ft.in. (mm)	11' 4" (3445)

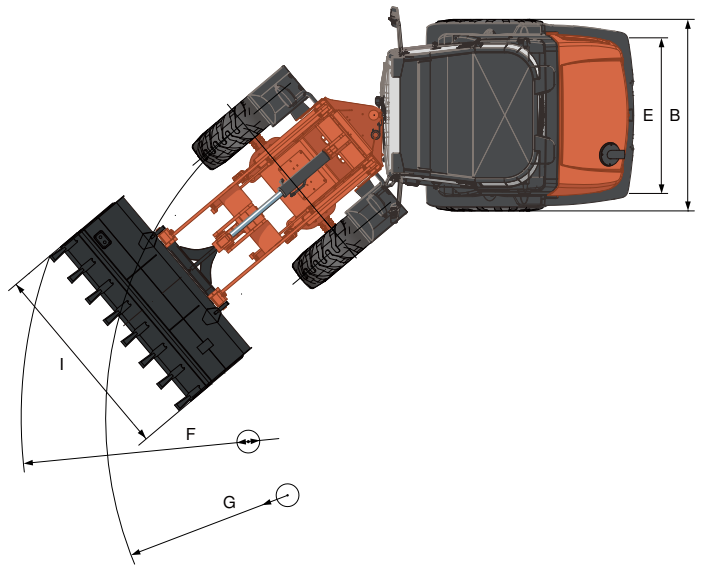

BUCKET SPECIFICATIONS

H	Overall length	ft.in. (mm)	17' 0" (5185)
I	Bucket width	in. (mm)	75.5" (1918)
J	Height to hinge pin	ft.in. (mm)	10' 8" (3250)
K	Dump clearance	ft.in. (mm)	8' 3" (2525)
L	Reach fully raised	ft.in. (mm)	2' 6" (760)
M	Digging depth	in. (mm)	2.2" (56)
N	Dump angle fully raised	Deg.	45
O	Rollback at traveling position	Deg.	52

PALLET FORK SPECIFICATIONS

Fork length	in. (mm)	47" (1200)	
A1	Overall length	ft.in. (mm)	19' 0" (5790)
B1	Height of forks at Max. reach	ft.in. (mm)	4' 6" (1380)
C1	Height of forks at Max. height	ft.in. (mm)	10' 0" (3045)
D1	Reach at ground level	ft.in. (mm)	2' 7" (780)
E1	Max. reach	ft.in. (mm)	4' 1" (1235)
F1	Reach at Max. height	ft.in. (mm)	1' 7" (475)

Note: The above dimensions are based on the machine with std. tires, Euro type quick coupler, standard bucket or standard pallet fork and ROPS/FOPS canopy and cabin.

★ All images shown are for brochure purposes only.

When operating the wheel loader, wear clothing and equipment in accordance to local legal and safety regulations.

SPECIFICATIONS

Model		R630		
Type of ROPS / FOPS		CANOPY / CAB		
Engine	Model		V2607-CR-TE4	
	Emission certification		Tier4 Final	
	Output (SAE J1995 gross)	HP (kW)/rpm	64.4 (48.0) / 2400	
	Output (SAE J1349 net)	HP (kW)/rpm	61.2 (45.6) / 2400	
	Displacement	cu.in. (cc)	160 (2615)	
Transmission	Type		Hydrostatic transmission	
Dimensions	Overall length	ft.in. (mm)	17' 0" (5185)	
	Overall height	ft.in. (mm)	8' 2" (2480) / 8' 2" (2500)	
	Overall width (w/o bucket)	ft.in. (mm)	5' 11" (1805)	
	Ground clearance	in. (mm)	13.8" (350)	
Auxiliary circuit	Auxiliary hydraulic flow	gpm (ℓ/min.)	17.8 (67.2)	
	Auxiliary hydraulic pressure	psi (Mpa)	3000 (20.6)	
Drive system	Tire size		405/70R18	
	Travel speed	Low / High	mph (km/h)	3.0 (4.8) / 12.4 (20.0)
	Max. traction force		lbs. (kN)	8593 (38.2)
	Front/Rear axle traction lock		Diff-lock (both axles)	
	Articulation angle		deg.	40 (each direction)
	Angle of rear frame oscillation		deg.	±8
	Loader clearance circle		ft.in. (mm)	27' 3" (8295)
	Turning radius track circle		ft.in. (mm)	11' 4" (3445)
	Brakes	Service		Enclosed wet disc
		Parking		Spring applied hydraulic released wet disc
Lifting specifications	Tipping load (straight)	with bucket	lbs. (kg)	7606 (3450) / 8212 (3725)
		with pallet forks	lbs. (kg)	5842 (2650) / 6305 (2860)
	Tipping load (full turn)	with bucket	lbs. (kg)	6459 (2930) / 7000 (3175)
		with pallet forks	lbs. (kg)	4993 (2265) / 5390 (2445)
	Rated operating capacity (SAE)	with bucket	lbs. (kg)	3229 (1465) / 3500 (1587)
		with pallet forks	lbs. (kg)	2496 (1132) / 2695 (1222)
Operational specifications	Standard bucket capacity		yd ³	1.0
	Breakout force		lbs. (kN)	10415 (46.3)
	Lifting capacity at ground level		lbs. (kN)	8505 (37.8)
	Loader raise / lower time		sec.	5.9 / 4.2
Fuel tank		gal. (ℓ)	18.5 (70)	
Hydraulic system		gal. (ℓ)	15.1 (57)	
Hydraulic reservoir		gal. (ℓ)	10.3 (39)	
Operating weight (Including operator weight @ 175lbs.)		lbs. (kg)	10229 (4640) / 10725 (4865)	

Note: The above dimensions are based on the machine with std. tires, Euro type quick coupler, standard bucket and ROPS/FOPS canopy and cabin. The company reserves the right to change the above specifications without notice. This brochure is for descriptive purposes only. Please contact your local Kubota dealer for warranty information. For your safety, Kubota strongly recommends the use of a Rollover Protective structure (ROPS) and seat belt in almost all applications.

R630 OPTIONS

STANDARD EQUIPMENT

Safety

- 6 Tie down points
- Lift arm support
- Towing pin

Working equipment

- 2 Head lights (Headlights and Signal Lights)
- Hybrid link system
- Rear combination light
(Turn signal, Tail light, Brake light, Backup light)

Operator's space

- Weight-adjustable suspension seat (PVC seat) with left arm rest and back rest
- Retractable seatbelt
- Adjustable right wrist rest
- Digital panel with diagnostic function
- ROPS (Roll-over Protective Structure, ISO3471)
- FOPS (Falling Object Protective Structure, Level1, ISO3449)
- Side mirrors
- 12V power outlet
- Tool storage space - Canopy models
- Tilt steering
- Cup holder

Engine/Fuel system

- KUBOTA original engine
- Double-element air cleaner
- Fuel level indication buzzer
- Fuel / water separator
- Separate fuel filter

Travel system

- Five travel speeds
- Differential lock
(100% on demand, front and rear)
- Wet type disc brake
- Negative brake (parking brake)
- 405/70R18 tire

Hydraulic system

- 4 operating mode selections by electronic hydrostatic transmission (Normal, Power, Eco, Attachment modes)
- Multi-function operating lever with AUX proportional control
- Hydraulic lock switch
- Auxiliary hydraulics flow hold switch
- Inching and brake pedal (left)
- Hydraulic quick coupler switch
- Engine speed (Auxiliary hydraulics flow) control dial
- Loader float switch

Others

- Maintenance free battery
- Grease gun holder
- Radio ready

OPTIONAL EQUIPMENT

- Cab with air conditioner
- Beacon light
- Inching and brake pedal (right)
- Kubota Shockless Ride (KSR)
- Tool box for cab models
- Rear working lights
- Various buckets and other attachment
- Block heater
- 3" retractable seat belt
- Hydraulic Euro-type coupler
- Hydraulic SSL-type coupler
- Mechanical SSL-type coupler

©2014 Kubota Corporation



KUBOTA TRACTOR CORPORATION

Kubota Tractor Corporation, 3401 Del Amo Boulevard, Torrance CA 90503
Western Division: 1175 S. Guild Ave., Lodi, CA 95240 Tel (209) 334-9910
Central Division: 14855 FAA Boulevard, Fort Worth, TX 76155 Tel (817) 571-0900
Northern Division: 6300 at One Kubota Way, Groveport, OH 43125 Tel (614) 835-1100
Southeast Division: 1025 Northbrook Parkway, Suwanee, GA 30024 Tel (770) 995-8855

Visit our web site at: www.kubota.com

